

Modular Cooking Range Line 900XP One Well Electric Fryer 18 liter

ITEM # _____

MODEL # _____

NAME # _____

SIS # _____

AIA # _____



- | | |
|----------------------------|---|
| 391094 (E9FRED1HF0) | 18-lt electric Fryer with 1 well and 2 half size baskets, internal heating elements |
| 391178 (E9FRED1HFN) | 18-lt electric Fryer with 1 well and 2 half size baskets, internal heating elements |

Short Form Specification

Item No. _____

High efficiency tilting incoloy armoured heating elements (16.5kW) placed inside the well. Deep drawn well. Oil drains through a tap into a container positioned under the well. Height adjustable feet in stainless steel. Exterior panels in stainless steel. Worktop in 20/10, stainless steel. Right-angled side edges eliminate gaps and possible dirt traps between units.

Main Features

- Thermostatic regulation of oil temperature up to a maximum of 185 °C.
- Overheat protection thermostat as standard on all units.
- Oil drains through a tap into a drainage container positioned under the well.
- All major compartments located in front of unit for ease of maintenance.
- IPX5 water resistance certification.
- The special design of the control knob system guarantees against water infiltration.
- Unit delivered with four 50 mm legs in stainless steel as standard (all round Stainless steel kick plates as option).
- Supplied as standard with 2 half size baskets and 1 right side door for cupboard.
- Incoloy armoured heating elements located inside the well can be lifted up for easier cleaning.
- Optional portable oil quality monitoring tool (code 9B8081) for efficient oil management.

Construction

- Unit is 930 mm deep to give a larger working surface area.
- All exterior panels in Stainless Steel with Scotch Brite finishing.
- Model has right-angled side edges to allow flush fitting joints between units, eliminating gaps and possible dirt traps.
- Interior of well with rounded corners for ease of cleaning.

Included Accessories

- 1 of Door for open base cupboard PNC 206350
- 1 of 2 half size baskets for 18/23 lt fryers PNC 927223

Optional Accessories

- Junction sealing kit PNC 206086
- Flanged feet kit PNC 206136
- Frontal kicking strip for concrete installation, 400mm PNC 206147
- Frontal kicking strip for concrete installation, 800mm PNC 206148
- Frontal kicking strip for concrete installation, 1000mm PNC 206150
- Frontal kicking strip for concrete installation, 1200mm PNC 206151
- Frontal kicking strip for concrete installation, 1600mm PNC 206152

APPROVAL: _____

- Pair of side kicking strips for concrete installation PNC 206157
- Frontal kicking strip, 400mm (not for refr-freezer base) PNC 206175
- Frontal kicking strip, 800mm (not for refr-freezer base) PNC 206176
- Frontal kicking strip, 1000mm (not for refr-freezer base) PNC 206177
- Frontal kicking strip, 1200mm (not for refr-freezer base) PNC 206178
- Frontal kicking strip, 1600mm (not for refr-freezer base) PNC 206179
- Pair of side kicking strips (not for refr-freezer base) PNC 206180
- 2 panels for service duct for single installation PNC 206181
- 2 panels for service duct for back to back installation PNC 206202
- Kit 4 feet for concrete installation (not for 900 line free standing grill) PNC 206210
- Chimney upstand, 400mm PNC 206303
- Back handrail 800 mm PNC 206308
- Back handrail 1200 mm PNC 206309
- Door for open base cupboard PNC 206350
- Filter (inox) for fryer oil collection basin for 18lt, 23lt free standing fryers (without oil recirculation pump) PNC 206359
- Base support for feet or wheels - 400mm (700/900) PNC 206366
- Base support for feet or wheels - 800mm (700/900) PNC 206367
- Base support for feet or wheels - 1200mm (700/900) PNC 206368
- Base support for feet or wheels - 1600mm (700/900) PNC 206369
- Base support for feet or wheels - 2000mm (700/900) PNC 206370
- Rear paneling - 600mm (700/900XP) PNC 206373
- Rear paneling - 800mm (700/900) PNC 206374
- Rear paneling - 1000mm (700/900) PNC 206375
- Rear paneling - 1200mm (700/900) PNC 206376
- Base support for feet/wheels (600mm) PNC 206431
- 2 side covering panels for free standing appliances PNC 216134
- 2 half baskets for 18lt fryers with front hook PNC 927200
- 1 full basket for 18lt fryers with front hook PNC 927201
- 2 half size baskets for 18/23 lt fryers PNC 927223
- 1 full size basket for 18/23 lt fryers PNC 927226

Front

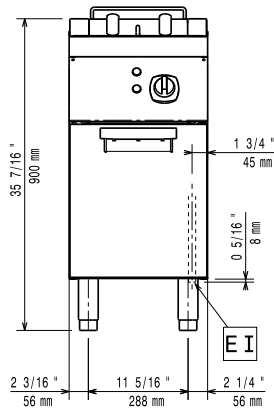

Side

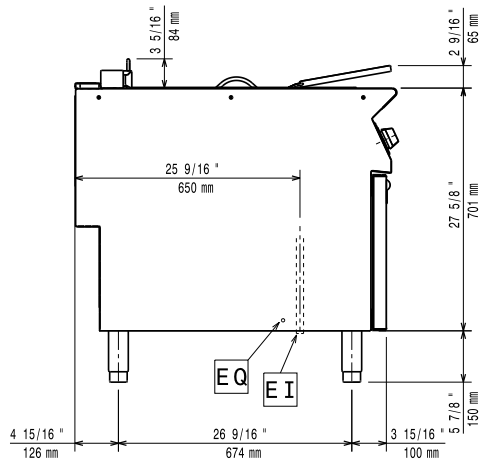

EI = Electrical inlet (power)
 EQ = Equipotential screw

Top

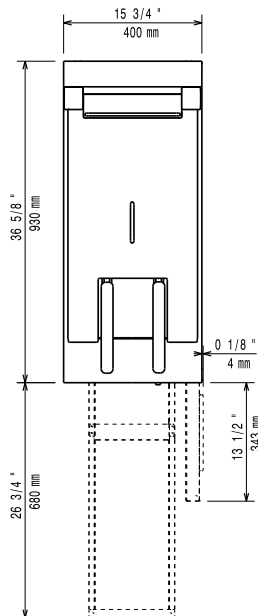

Electric

Supply voltage:

391094 (E9FRED1HF0)

380-400 V/3N ph/50/60 Hz

391178 (E9FRED1HFN)

230 V/3 ph/50/60 Hz

Total Watts:

16.5 kW

Predisposed for:

391094 (E9FRED1HF0)

380-400V 3N- 50/60Hz
15-16,5kW

Key Information:

Usable well dimensions (width):

340 mm

Usable well dimensions (height):

290 mm

Usable well dimensions (depth):

400 mm

Well capacity:

18 lt MIN; 20 lt MAX

Thermostat Range:

105 °C MIN; 185 °C MAX

Net weight:

57 kg

Shipping weight:

391094 (E9FRED1HF0)

60 kg

391178 (E9FRED1HFN)

62 kg

Shipping height:

391094 (E9FRED1HF0)

1080 mm

391178 (E9FRED1HFN)

1120 mm

Shipping width:

460 mm

Shipping depth:

1020 mm

Shipping volume:

391094 (E9FRED1HF0)

0.51 m³

391178 (E9FRED1HFN)

0.53 m³

Certification group:

391094 (E9FRED1HF0)

EF19118

391178 (E9FRED1HFN)

N9FE3

If appliance is set up or next to or against temperature sensitive furniture or similar, a safety gap of approximately 150 mm should be maintained or some form of heat insulation fitted.