



SCRW15 (Frameless Canopy and Rear Sliding Door options)

SOMERSET RW: CHILLED AIR CURTAIN

This stylish air curtain cabinet is ideal for display of gourmet and patisserie foods. Installed within compatible joinery it brings class to your food offering.

4°C operating temperature

STANDARD FEATURES

- › Fan assisted cold air blanket across top of well
- › Stainless steel well
- › Raised well (**RW**) to allow displayed food to sit higher
- › Height of well can be **75** or **100mm**
- › **DuraCoat** system providing a protective coating over the refrigeration coil to prevent food acid corrosion
- › Refrigeration unit provided as Integral (condenser in cradle)
- › Designed to operate at 3-5°C in room environments up to 22°C
- › For open canopies there should be no air movement across the open well
- › Elegant stainless steel gantry
- › Planar glass canopy as standard
- › Designer overhead **SlimLED** lighting system with 12V safety
- › Defrost drainage to container or plumbed to waste

For Sneeze-Guard and glass canopy options refer to page 58

For Factory Options refer to page 60

For Cabinet Accessories refer to page 66

SIDE VIEW

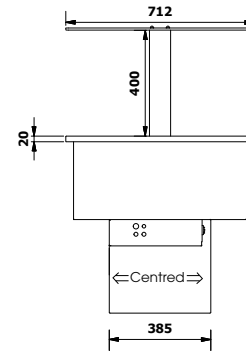

REAR VIEW

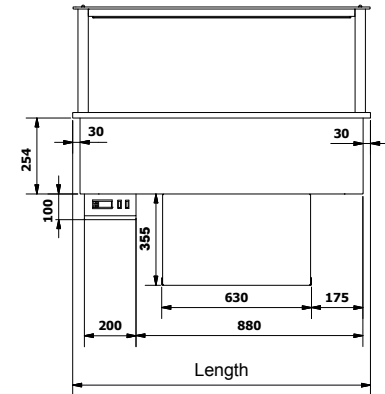

Model	SCRW12	SCRW15	SCRW18	SCRW21
Length	1155mm	1480mm	1805mm	2130mm
Depth*	712mm	712mm	712mm	712mm
Internal Well Height	75/100mm	75/100mm	75/100mm	75/100mm
Canopy Height Above Counter*	430mm	430mm	430mm	430mm
Power Connection	10A Plug	10A Plug	10A Plug	10A Plug

***For Planar canopy option**