



CCI12
(Front sliding door option)

STANDARD FEATURES

- › **FrameFree** canopy that maximises fully the visibility of displayed food from all sides
- › Refrigeration unit provided as condenser in cradle
- › Three food display levels: two shelves plus bottom trays
- › Chrome wire shelving system that is height adjustable in 25mm increments and interchangeable between horizontal and tilted positions
- › **CrumbCatch** feature in bottom trays that collects falling crumbs and food
- › High quality European and Japanese refrigeration components
- › Refrigeration unit provided as condenser in cradle
- › Fan forced air flow for even temperature distribution
- › **ClearView** front glass for condensation control
- › Refrigeration optimised to provide a high humidity environment that maintains food quality for longer
- › **DuraCoat** system providing a protective coating over the refrigeration coil to prevent food acid corrosion
- › **SureVap** self-evaporating system for condensate—no drain required
- › **SlimLED** under-shelf LED strip lighting with 12V safety
- › Rear sliding, double-glazed doors on friction-free, low wear tracks (doors removable for cleaning)

For Factory Options refer to page 60

For Cabinet Accessories refer to page 66

REAR VIEW

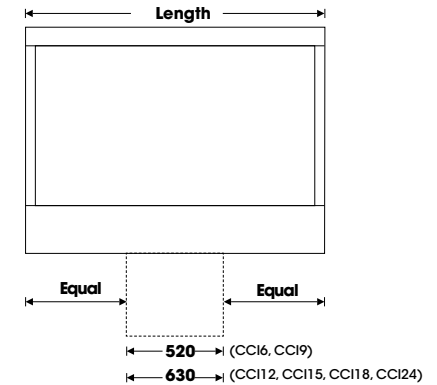

SIDE VIEW

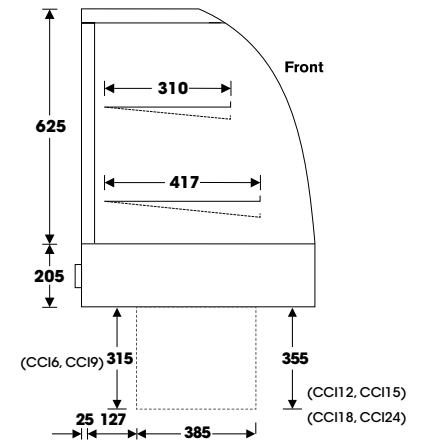

CORNWALL: CHILLED INTEGRAL

An elegant counter-top cabinet designed to maximise display area, show food with style, and maintain food at the highest quality.

4°C operating temperature

Climate class 3M1 (25°C/60%RH)

Model	CCI6	CCI9	CCI12	CCI15	CCI18	CCI24
Length	600mm	900mm	1200mm	1530mm	1770mm	2370mm
Depth*	640mm	640mm	640mm	640mm	640mm	640mm
Height	830mm	830mm	830mm	830mm	830mm	830mm
Available Display Area	0.63m ²	1m ²	1.37m ²	1.78m ²	2.03m ²	2.77m ²
Power Connection	10A Plug	10A Plug	10A Plug	10A Plug	10A Plug	10A Plug

*Add extra 30mm for protruding control panel and switches